



APPLICATION NOTE

WILL MY LOCATOR OR PULSER GFL DAMAGE CUSTOMER EQUIPMENT?

We are often asked if the high voltages produced by some testers like cable locators or ground fault locators will damage equipment in the system being detected. The answer is no as long as the tester is connected in a way that avoids stressing parts of the system.

Modern irrigation and landscape lighting systems use electronic components for efficiency. These components (LED lamps, sensors, irrigation decoders) are susceptible to damage from high voltages and have to be protected. The system wires are usually buried, so a wire locator like one from the Pro series from Armada is an important maintenance tool. Care is required because locators can produce over 100 volts AC at a low current.

When tracking the wires there are several important things to keep in mind:

- Before connecting the locator transmitter, remove the two cable wires from the transformer or controller. See below. The high power of the transmitter could damage the controller.
- Tie the two wires in the cable together and connect the Red transmitter lead to them. This insures a good tracing path and avoids damage to lighting fixtures, decoders or sensors from the high voltage of the transmitter.
- Connect the Black transmitter lead to ground using the ground stake. Turn on the transmitter and adjust the output for at least half-scale on the meter (Pro700 and 800) or an 'OK' (900). This shows that tracing current is flowing and can be detected by the receiver.

This kind of connection ensures that no high voltages are applied to electronic components. See the irrigation illustration. Turn on the receiver wand and begin following the tracing tone down the wire path.

Locators are safe to use around incandescent and LED low voltage lighting systems, or decoder-based irrigations systems when connected this way.

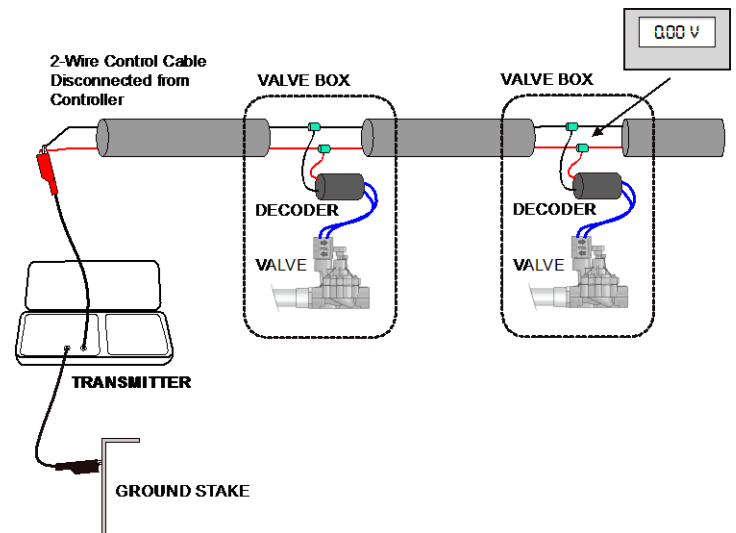

Shock hazard - Avoid touching the transmitter wires and traced cable when the transmitter is on. There is a voltage between them and ground.